

Acceval VEB-51

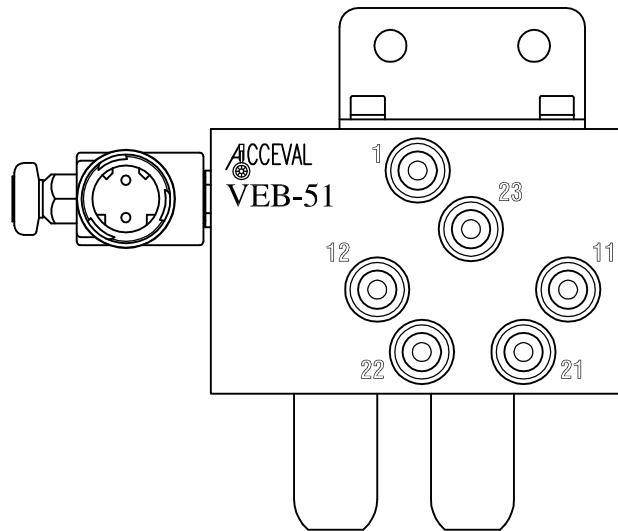

Lift Axle Control Valve
Electrically Commanded
From EBS System

For Suspensions with
Double Circuit

ACCEVAL VEB-51

LIFT AXLE CONTROL VALVE
FOR EBS SYSTEM

(SUSPENSION: DOUBLE CIRCUIT)

EXTERNAL DIMENSIG

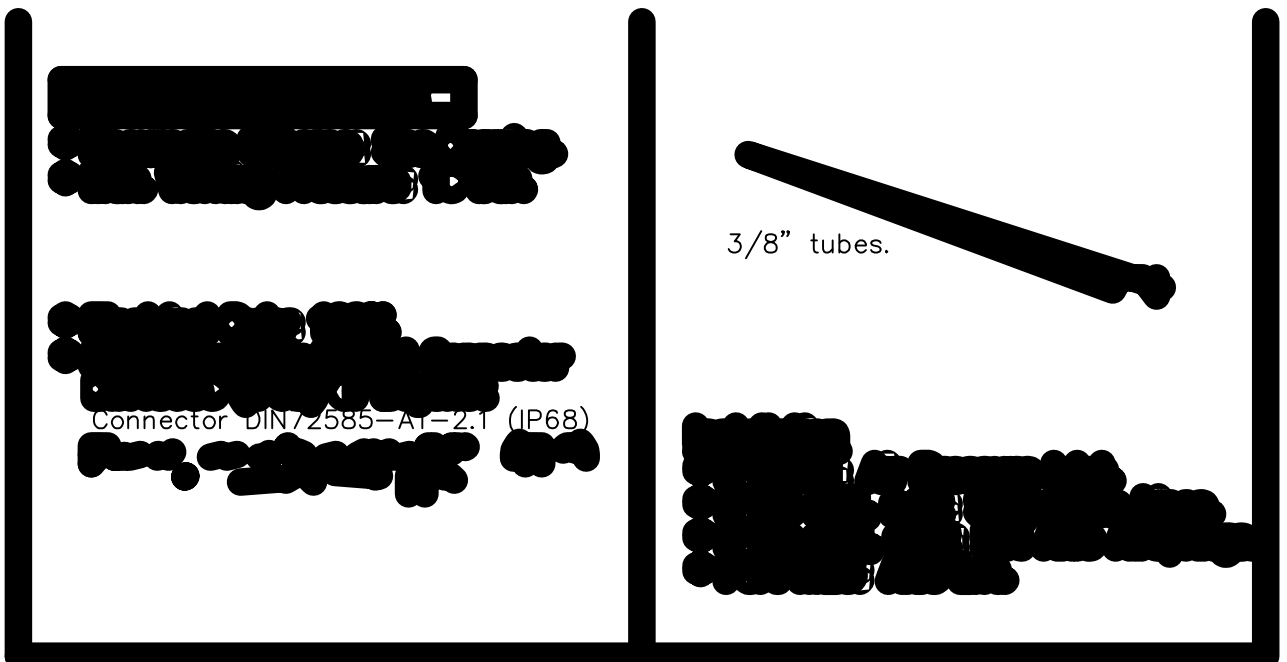
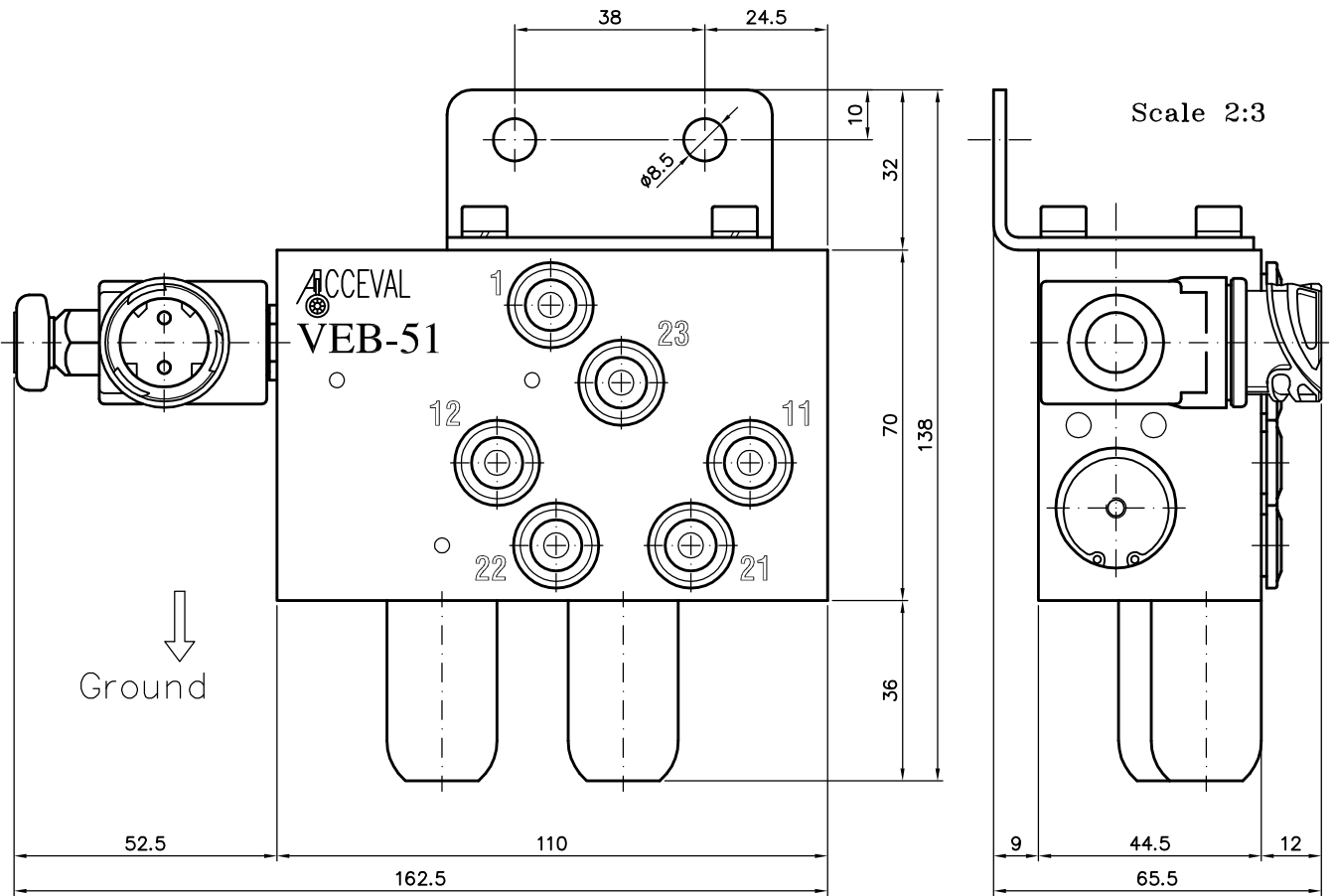

ACCEVAL VEB-51
BASIC CONNECTIONS SCHEME
 (Suspension: Double Circuit)

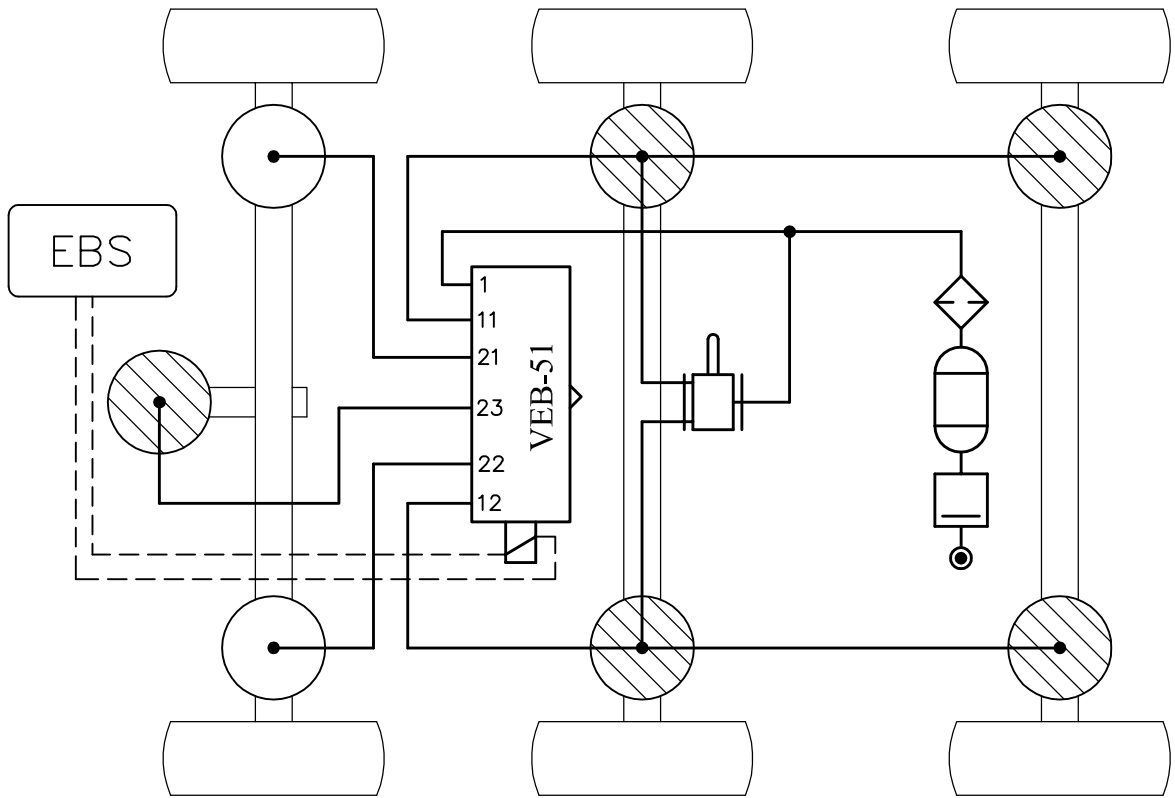

ACCEVAL VEB-51
PNEUMATICAL SCHEME
 (Suspension: Double Circuit)

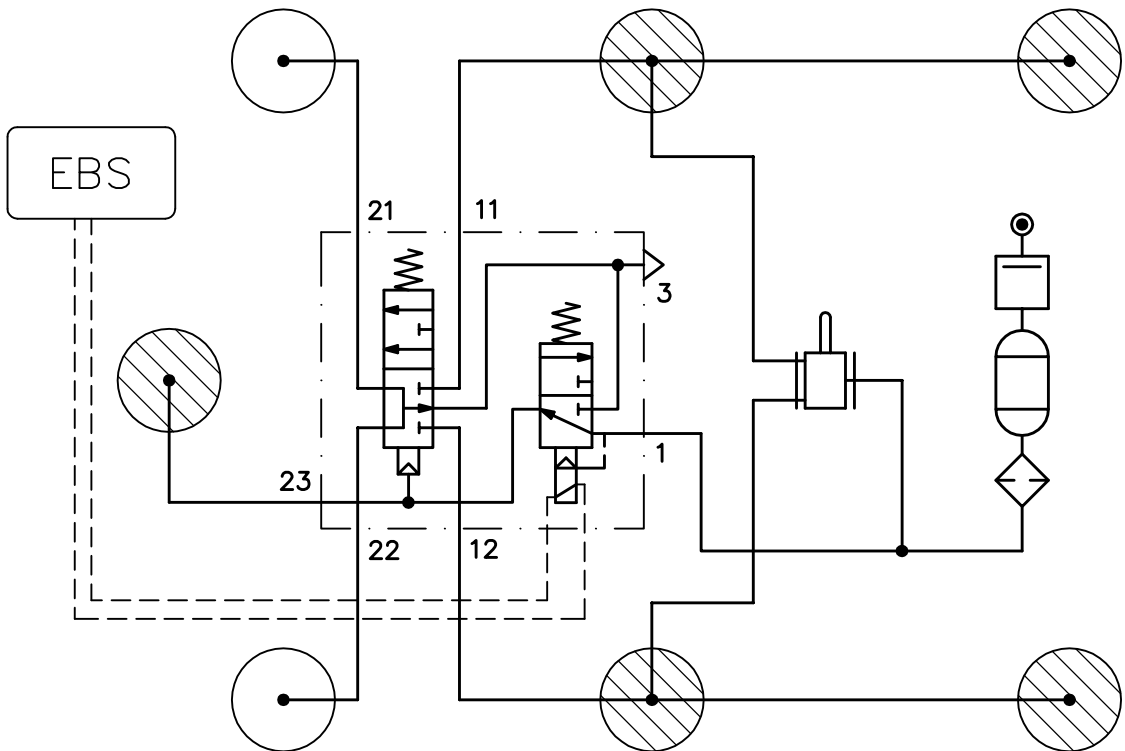

VERSIONS AND ANCHORING ORIENTATION

THE BEST ORIENTATION

File

ACCEPTABLE ORIENTATION

Ground ↓

Ground ↓